

HYDRAULIC DISC BRAKES LB, LBS, LBV- Wet



APPLICATION

- » Heavy Duty machinery
- » Wheel drives
- » Material handling
- » Mining
- » Agricultural machines
- » Conveyors
- » Door openers and swing drives etc.



GENERAL

Fluid type	Mineral based- HLP(DIN 51524) or HM(ISO 6743/4)
Temperature range, °C [°F]	-40÷140 [-40÷284]
Viscosity range, mm²/s	20÷75 [98÷347]
Filtration	ISO code 20/16 (nominal filtration of 25 microns)
Maintenance	Changed after the first 50-100 h, then after every 500-1500 h.

CONTENTS

Hydraulic Disc Brake for MP, MR and MS Motors type LB/288	4÷5
Hydraulic Disc Brake for MSS and MSV type LBS(V)/289	6
Hydraulic Disc Brake for MSS and MSV type LBS(V)/290	7
Output Shafts for LBS(LBV)/289, 290	8
Specification data for LBS(LBV)/289, 290	8
Load curve for LBS(LBV)/289, 290	8
Internal Spline data for .../289,290 and .../314,315.....	9
Order code for LB/288,LBS(LBV)/289, 290	9
Hydraulic Disc Brake for MTS and MTV type LBS(LBV)/314	10
Hydraulic Disc Brake for MTS and MTV type LBS(LBV)/315	11
Specification data for LBS(LBV)/314, 315	12
Load curve for LBS(LBV)/314, 315	12
Output Shafts for LBS(LBV)/314, 315	13
Order code for LBS(LBV)/314, 315	13
Hydraulic Disc Brake for MVS type LBS/313	14
Load curve for LBS/313	14
Hydraulic Disc Brake for MVS type LBS/316	15
Load curve for LBS/316	15
Specification data for LBS/313, 316.....	16
Output Shafts for LBS/313, 316	16
Internal Spline data for LBS/313, 316	17
Order code for LBS/313, 316	17

LB, LBS

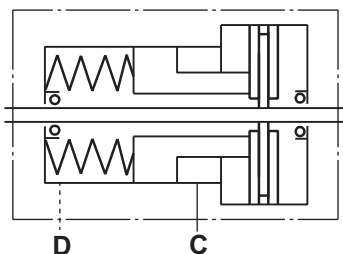

LBV

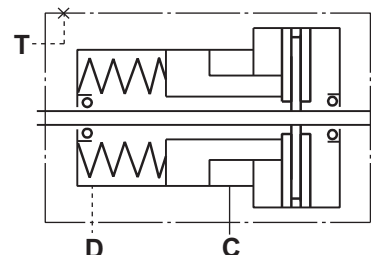

HYDRAULIC DISC BRAKE FOR FLANGE ATTACHMENT TO MSS AND MSV HYDRAULIC MOTORS

TYPE LBS/289

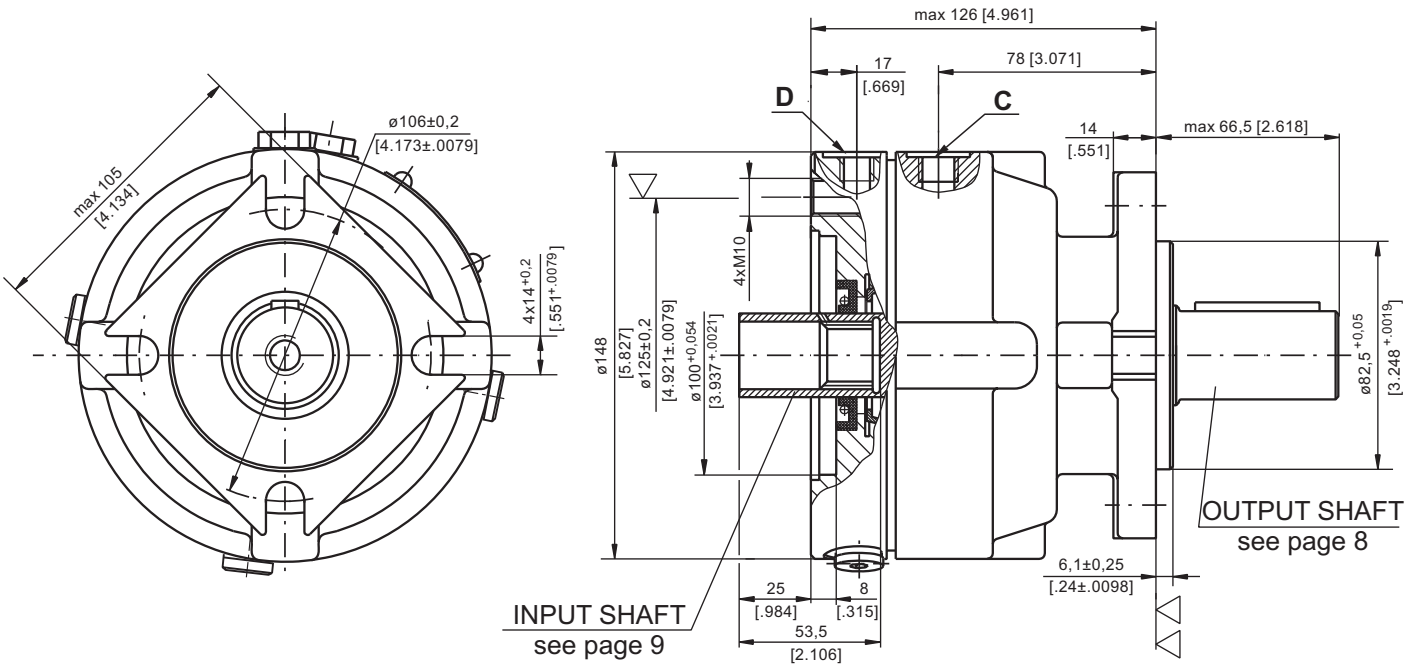

▽ - Place for attachment (tightening torque for screw M10x35 - 8.8 DIN 912 - 5 daNm [440 lb-in])

▽▽ - Place for attachment



TYPE LBV/289

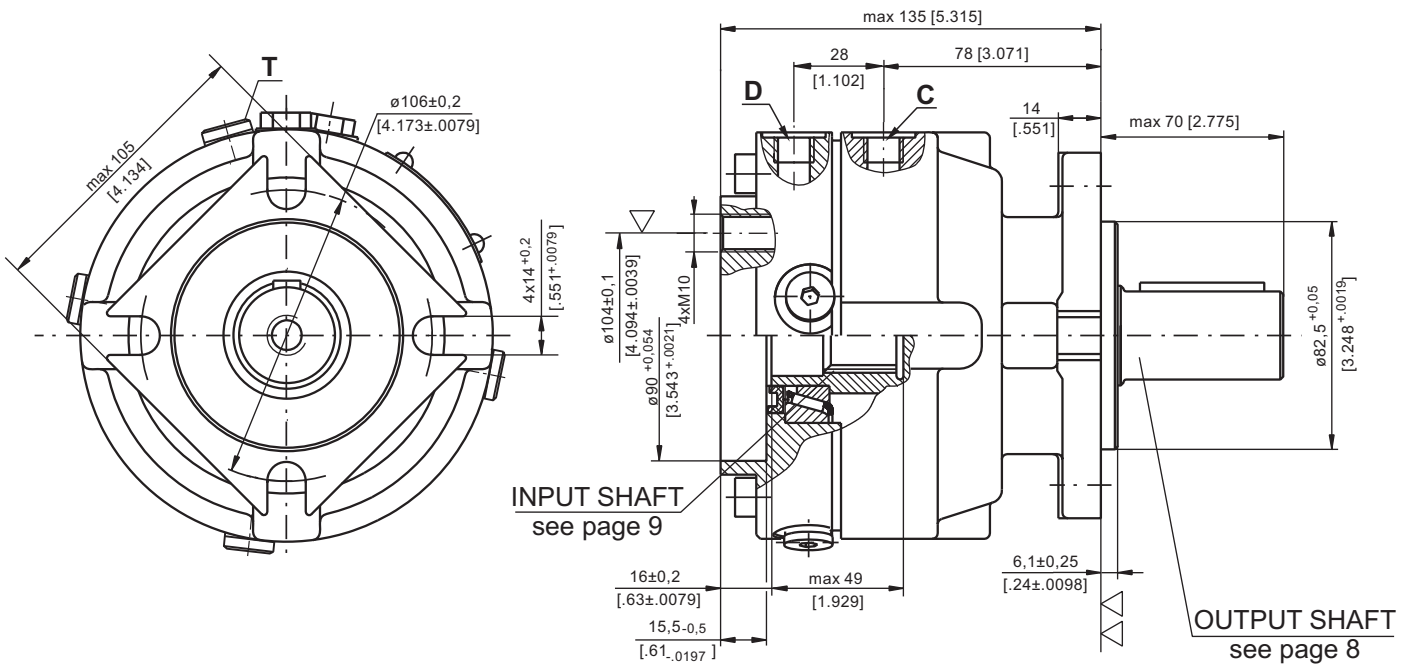

▽ - Place for attachment (tightening torque for screw M10 - 8.8 DIN 912 - 5 daNm [440 lb-in])

▽▽ - Place for attachment

C : Brake release Port - G $\frac{1}{4}$, 9 mm [.35 in] depth

D, T: Drainage tap - G $\frac{1}{4}$, 9 mm [.35 in] depth

**HYDRAULIC DISC BRAKE FOR FLANGE ATTACHMENT
TO MSS AND MSV HYDRAULIC MOTORS**

TYPE LBS/290

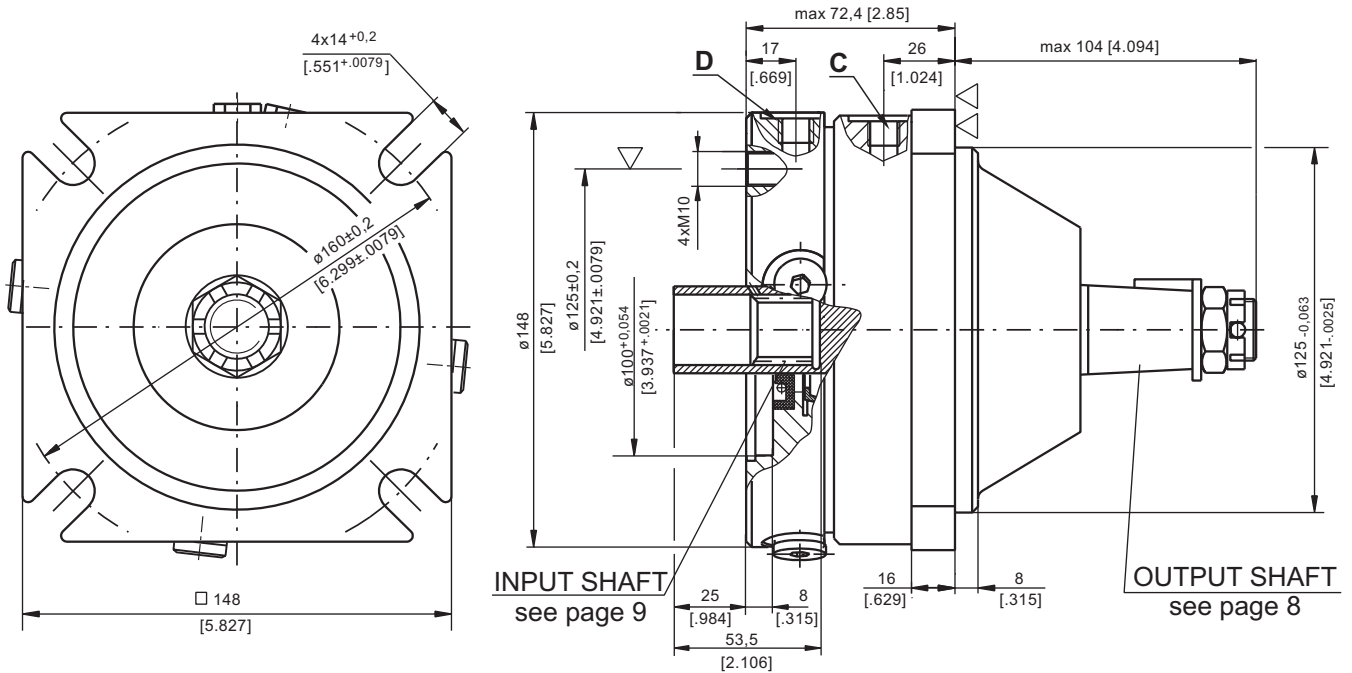

▽ - Place for attachment
(tightening torque for screw M10x35 - 8.8 DIN 912 - 5 daNm [440 lb-in])

▽▽ - Place for attachment



TYPE LBV/290

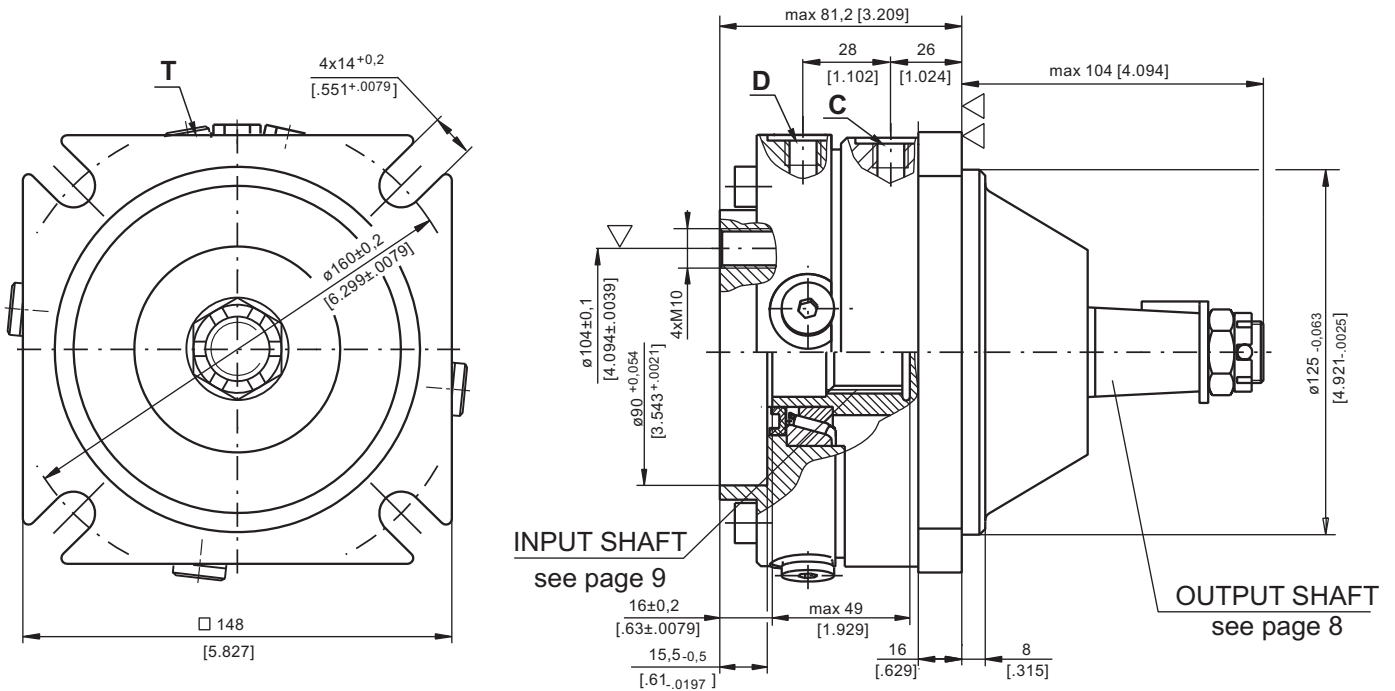

▽ - Place for attachment
(tightening torque for screw M10 - 8.8 DIN 912
- 5 daNm [440 lb-in])

C : Brake release Port - G $\frac{1}{4}$, 9 mm [.35 in] depth

D, T: Drainage tap - G $\frac{1}{4}$, 9 mm [.35 in] depth

▽▽ - Place for attachment

OUTPUT SHAFT EXTENSIONS

CB - $\phi 32$ straight, Parallel key A10x8x45 DIN 6885
Max. Torque 77 daNm [6815 lb-in]

KB - tapered 1:10, Parallel key B6x6x20 DIN 6885
Max. Torque 95 daNm [8400 lb-in]

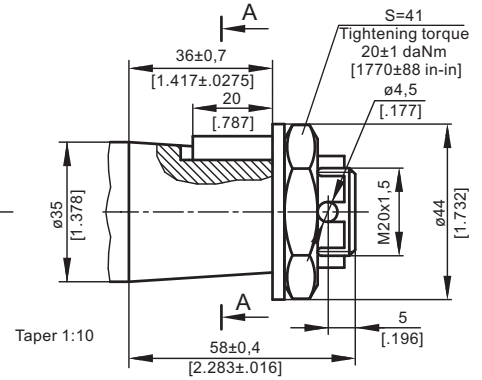
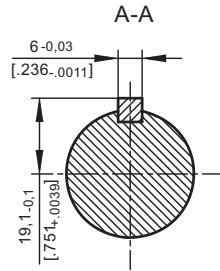
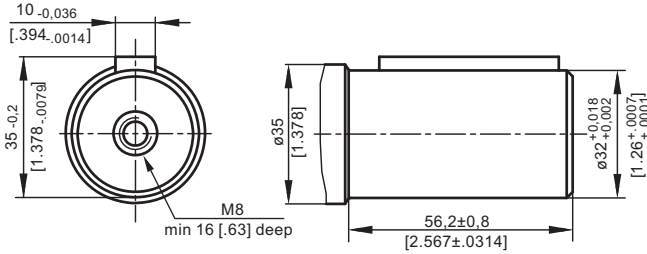

SPECIFICATION DATA

Description LBS/289(290) LBV/289(290)	21	32	43	63
*Min. Static Torque, daNm [lb-in]	20-22 [1770-1947]	31-34 [2743-3009]	41-45 [3628-3982]	61-64 [5399-5665]
Opening Pressure bar [PSI]	min 12-13 [174-188]	18-20 [260-290]	24-26 [348-377]	38-39 [550-565]
	max	300 [4350]		
Min. oil quantity for brake releasing cm ³ [in ³]	7 - 8 [.427 - .488]			
Oil volume cm ³ [in ³]	50 - 120 [3.05 - 7.35]			
Max. Pressure in drain space bar [PSI]	5 [72]			
Weight kg [lb]	9 [19.8]			

*Static torque is obtained at working pressure - 0 bar [0 PSI].

LOAD CURVE

The curve applies to a B10 bearing life of 3000 hours at 200 RPM.

- 1: Pa < 350 daN [787 lbs]
- 2: Pa = 500 daN [1125 lbs]

LBS(V)/289

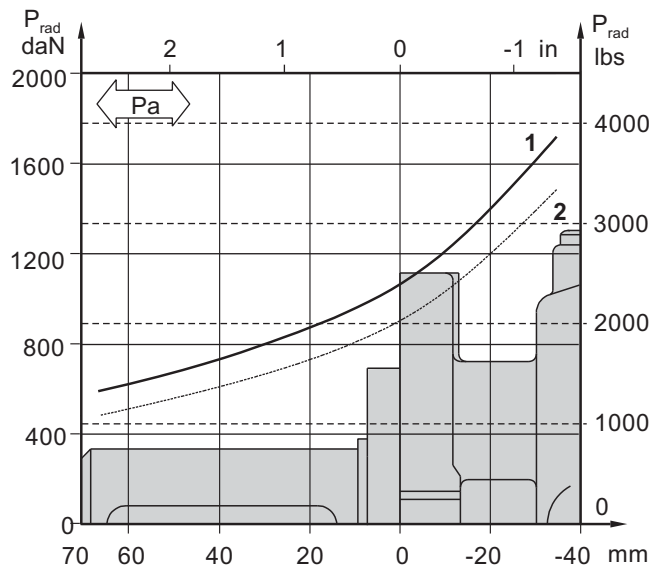

LBS(V)/290

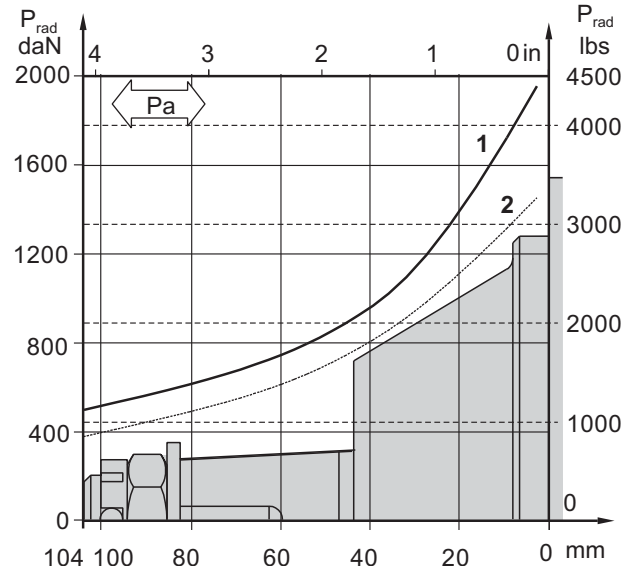

INTERNAL SPLINE DATA FOR THE ATTACHED COMPONENT

Standard ANS B92.1-1970, class 5

[m=2.1166]

Fillet Root Side Fit	LBS(V)/289 LBS(V)/290		LBS(V)/314 LBS(V)/315		
	mm	inch	mm	inch	
Number of Teeth	z	12	12	16	16
Diametral Pitch	DP	12/24	12/24	12/24	12/24
Pressure Angle		30°	30°	30°	30°
Pitch Dia.	D	25,4	1	33,8656	1.3333
Major Dia.	D _{ri}	28,0 ^{-0,1}	1.1 ± 1.098	38,4 ^{+0,4}	1.5118±1.5275
Minor Dia.	D _i	23,0 ^{+0,033}	.907 ± .905	32,15 ^{+0,06}	1.2657±1.2673
Space Width [Circular]	Lo	4,308±0,020	.1704 ± .1688	4,516±0,037	.1763±.1791
Fillet Radius	R	0,2	.008	0,5	.02
Max. Measurement between Pins	L	17,62 ^{+0,15}	.699 ± .694	26,9 ^{+0,10}	1.063±1.059
Pin Dia.	d	4,835±0,001	.19039±.19031	4,835±0,001	.19026±.19034
Corrected	x.m	+0,8	+0,031	+1,0	+0,039

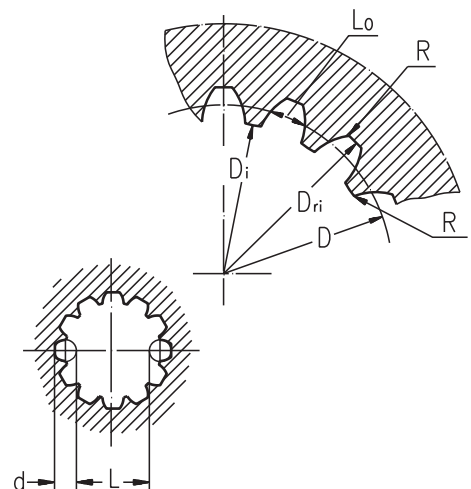

ORDER CODE - LB/288

	1	2	3	4	5
LB/288		-			

Pos.1 - Input Shaft Hole

C, CO, SH, CB, SB

- CB** - ø32 straight, Parallel key A10x8x45 DIN 6885
- KB** - ø35 tapered 1:10, Parallel key B6x6x20 DIN6885

Pos.2 - Static Torque code (See Specification data)

7, 14, 21, 32, 43, 63

Pos.4 - Option (Paint)**

- omit - no Paint
- P** - Painted
- PC** - Corrosion Protected Paint

Pos.3 - Output Shaft Extensions*

- C** - ø25 straight, Parallel key A8x7x32 DIN 6885
- CO** - ø1" straight, Parallel key ¼"x¼"x1¼" BS46
- SH** - ø25,32 splined BS 2059 (SAE 6B)
- SA** - ø24,5 splined B25x22 DIN 5482

Pos.5 - Design Series

- omit - Factory specified

ORDER CODE - LBS, LBV

	1	2	3	4	5	6
LB		/	-			

Pos.1 - Type

- S** - Disc Brake for short motor S- MSS
- V** - Disc Brake for very short motor V- MSV

Pos.4 - Output Shaft Extensions*

- CB** - ø32 straight, Parallel key A10x8x45 DIN 6885
- KB** - ø35 tapered 1:10, Parallel key B6x6x20 DIN6885

Pos.2 - Design code

- 289** - for MSS and MSV Motors
- 290** - for MSS and MSV Motors (Wheel Mount)

Pos.5 - Option (Paint)**

- omit - no Paint
- P** - Painted
- PC** - Corrosion Protected Paint

Pos.3 - Static Torque code (See Specification data)

21, 32, 43, 63

Pos.6 - Design Series

- omit - Factory specified

NOTES:

- * The permissible output torque for shafts must not be exceeded! For Max. Torque values see data on page 5 and 8.
- ** The color is by customer's request.

The Disc Brakes are mangano-phosphatized as standard.

ATTENTION:

1. Hydraulic brake is delivered without oil (it is lubricated only).
2. In all brakes, friction discs and separators should be lubricated. Space is filled with 50 ÷ 120 cm³ [3.05÷7.32 in³] mineral oil HLP (DIN 51524) or HM (ISO 6743/4). For LB/288 fill oil after hydraulic motor assembly.